

## Safety First



Disconnect saw from power source before fitting or removing insert.



Always wear proper ear protection when working with machinery.



Use caution when handling sharp objects (saw blades, router bits, drill bits and so on). Use protective gloves whenever possible.



Always wear proper eye protection when working with machinery and tools.



Always wear proper respiratory protection when working near airborne dust particles.

Please read and fully understand any and all safety materials that came with your power tools or machinery before operation. Always follow all safety guidelines set in place by the power tool or machine manufacturer.

## 1. Square up your saw blade

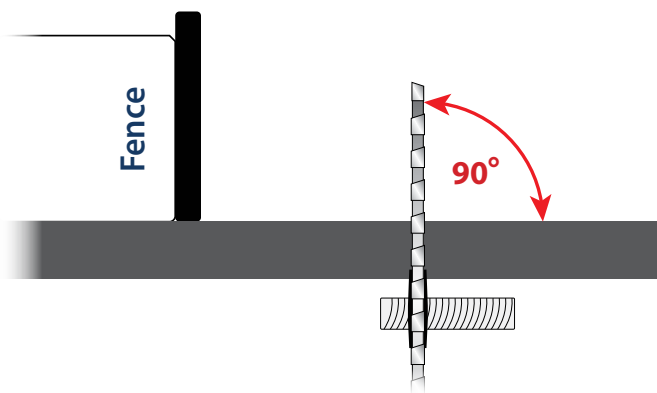

It is important to make sure that your table saw blade is square to your table top. If the blade is not square prior to the zero clearance installation process, the slot will be off and cannot be corrected once the slot cut is made.

## 2. Insert Placement & Proper Fitting

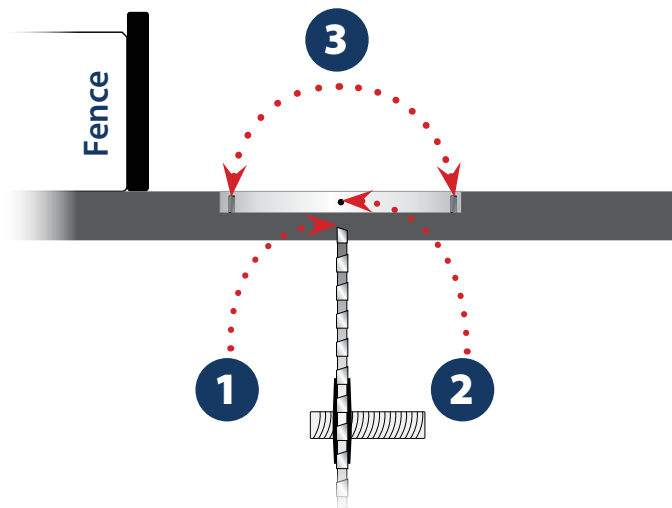

1. Lower the table saw blade completely. Place the insert into the table with pin (when applicable) pointing toward to the back end of the table saw.

**Shop Note:** If the insert doesn't sit flush because of the blade, remove the blade and replace it with a smaller diameter blade.

2. If the pin hits the solid part of the cast iron on the saw, drill a 1/4" hole in the saw for the pin to set in.

3. Adjust leveling screws down until the insert is stable and flush with the tabletop.

## Shop Tip: Cut out the Splitter/Riving Knife Slot



If your saw has a built in splitter or riving knife you need to cut a slot at the rear of the insert. Trace the outline of the slot from your original metal insert, and cut the slot with a bandsaw or a jigsaw. Leave the bridge between the splitter slot & the blade slot as thick as possible.

## 3. Cutting the saw blade kerf slot

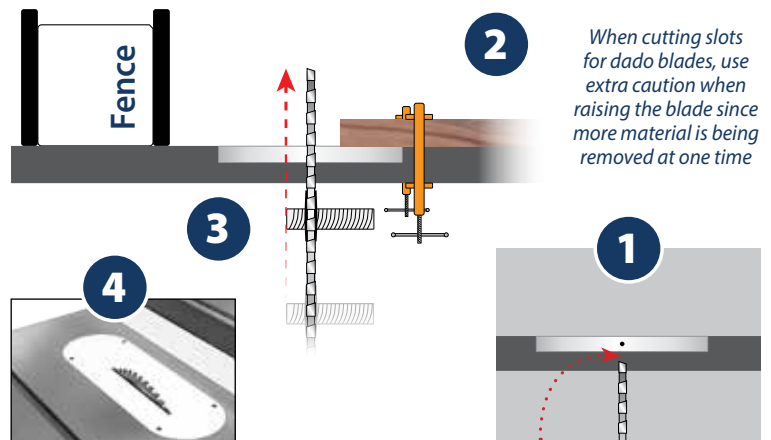

1. Check that the insert is fitted properly, and that the blade is clear of obstruction.

2. Partially cover the insert with a board as long as the tabletop, and clamp at each end to the table saw top. Make sure the board will NOT contact the blade as it passes through the insert.

3. Re-connect the power to the saw. Switch on, slowly raise the blade up to cut its way through the insert. Raise the saw blade to maximum cutting height.

**DO NOT STAND DIRECTLY BEHIND THE INSERT WHILE RAISING THE BLADE. KEEP HANDS OFF THE INSERT AND WOOD WHILE RAISING THE BLADE**

**Shop Note:** If you are using a smaller diameter blade, you must score the bottom of the insert enough to fit the full diameter size blade. Once scored, power down, unplug and swap out blades and follow the previous step 3 "Cutting the saw blade kerf slot" from the beginning.

4. Lower the blade, turn off saw and wait for blade to come to a complete stop, remove the board and your tablesaw zero clearance is ready for use!

# OOPS! I bought the wrong size insert...

If you accidentally purchased the wrong zero clearance insert, Please return to Fulton Woodworking Tools and Accessories at the following address:  
 Peachtree Woodworking Supply Inc.  
 Returns  
 6684 Jimmy Carter Blvd Suite 100  
 Peachtree Corners GA 30071  
**Please include the following information with the return:**  
 1. A paper tracing / outline of your factory zero clearance for correct matching purposes  
 2. Your telephone number  
 3. \$6.75 for shipping and handling



# U.H.M.W Zero Clearance Installation

*Shop Tip:  
 U.H.M.W. has it's own memory...*

U.H.M.W will absorb or remember the shape of the surface or objects it is resting on. If the insert has a slight bow or cup to it (1), simply rest the cup side up on the corner of a table (2) and apply pressure to both ends until the desired flatness is achieved (3).

**Please Note:** You may have to physically bend the insert past the cup in the opposite direction to achieve the proper flatness.

## 1. Cupped insert



## 2. Bend it to shape

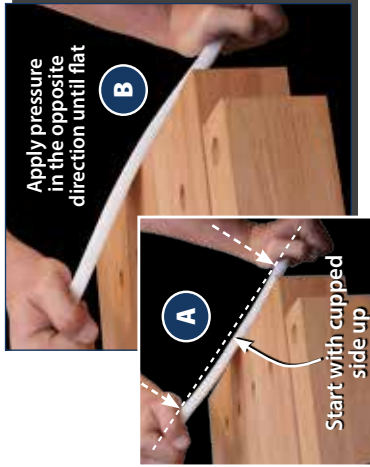

## 3. Flat Insert



## What does a zero clearance do?



Zero clearance inserts perform double duty once installed on your table saw. First and most importantly, the inserts prevent small pieces of stock from falling down between the blade and the insert (old factory insert with a sizeable gap). This helps prevent kick back. Kick back is one of the most dangerous outcomes while using a saw. Installing a zero clearance will minimize the chances of this occurring. The second duty that zero clearances perform is tearout prevention. The zero clearance insert provides support for your stock against the cutting edge. This virtually eliminates tearout.

## What is U.H.M.W?



U.H.M.W. stands for Ultra High Molecular Weight. This type of plastic can be milled or cut into many shapes and holds up much better than wood or other materials. U.H.M.W. is perfect for all types of jigs, fixtures, zero clearance inserts and more. This material provides a smooth, slick surface which makes it perfect for all types of applications. U.H.M.W. is very durable and the more you use it the slicker it becomes.

Please Note:

You must use carbide cutters when milling U.H.M.W.