

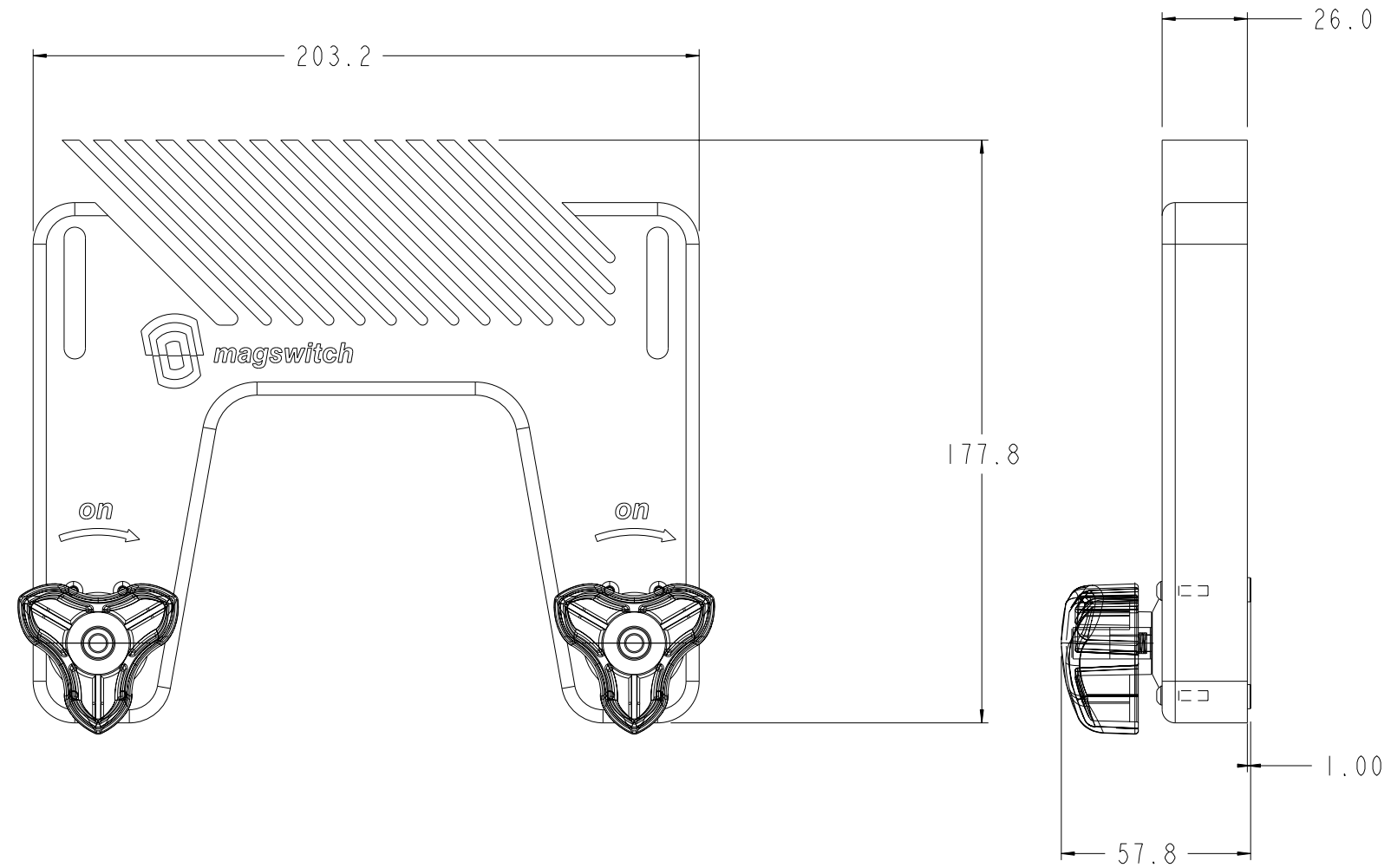

- 1) Apply loctite 222 or use preapplied screws.
- 2) Torque screws to 10±2 inlbs.
- 3) Torque knob to 20±2 inlbs
- 4) Verify actuation direction matches arrows.

<p><b>MAGSWITCH TECHNOLOGY, INC.</b> 8122 SOUTH PARK LANE, UNIT 112 LITTLETON, COLORADO 80120 (303) 468-0662 Fax: (303) 690-8144</p>	THIS DRAWING AND THE DATA CONTAINED HEREIN ARE CONFIDENTIAL AND THE EXCLUSIVE PROPERTY OF MAGSWITCH TECHNOLOGY INC. REPRODUCTION IS PROHIBITED WITHOUT WRITTEN APPROVAL FROM MTI. AND THE DRAWING AND DATA SHALL ONLY BE USED FOR THE SOLE PURPOSE OF MANUFACTURING ARTICLES FOR MTI		REV.	DATE	DESCRIPTION	BY	
	DRAFTED	John Fisher	DATE	5/1/06			
CHECKED				2	6/28/07	Change PN	CO
APPROVED				1	5/1/06	RELEASE	JF
R&D APPROVAL	PART DESCRIPTION.						
	30mm table feather board						
MATERIAL	PRODUCT NUMBER.						
	N/A						
COATING	N/A						REV.
							2
SHEET 1 OF 2	SCALE						
	NTS						



 <b>MAGSWITCH TECHNOLOGY, INC.</b> 8122 SOUTHPARK LANE, UNIT 112 LITTLETON, COLORADO 80120 (303) 468-0662 Fax: (303) 690-8144	THIS DRAWING AND THE DATA CONTAINED HEREIN ARE CONFIDENTIAL AND THE EXCLUSIVE PROPERTY OF MAGSWITCH TECHNOLOGY INC. REPRODUCTION IS PROHIBITED WITHOUT WRITTEN APPROVAL FROM MTI. AND THE DRAWING AND DATA SHALL ONLY BE USED FOR THE SOLE PURPOSE OF MANUFACTURING ARTICLES FOR MTI		REV.	DATE	DESCRIPTION	BY	
	DRAFTED	John Fisher	DATE	5/1/06			
CHECKED				2	6/28/07	Change PN	CO
APPROVED				1	5/1/06	RELEASE	JF
R&D APPROVAL	PART DESCRIPTION.						
	30mm table feather board						
MATERIAL	N/A	PRODUCT NUMBER.					
		8000328					
COATING	N/A					REV.	
						2	
SHEET 2 OF 2	SCALE	NTS					