

1

2

3

4

5

6

A

A

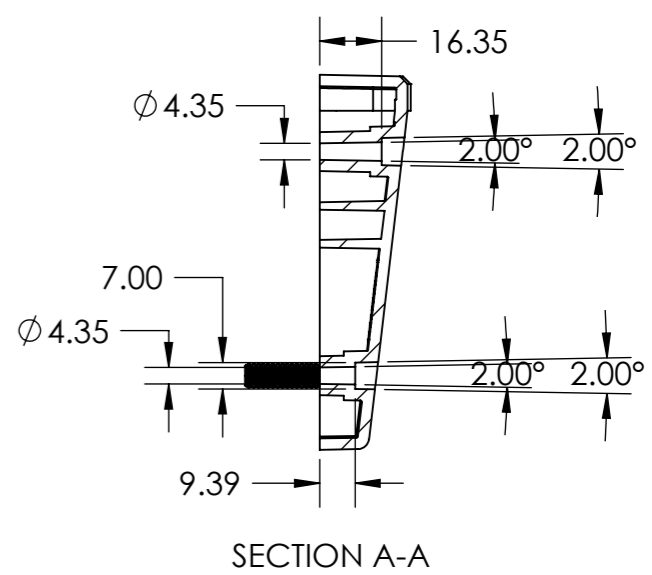
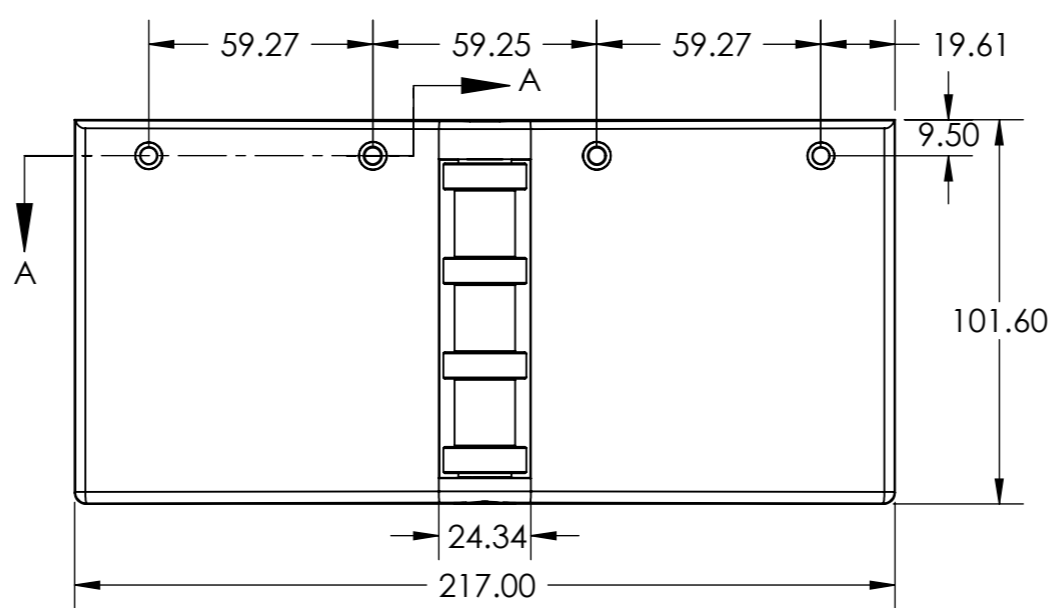

B

B

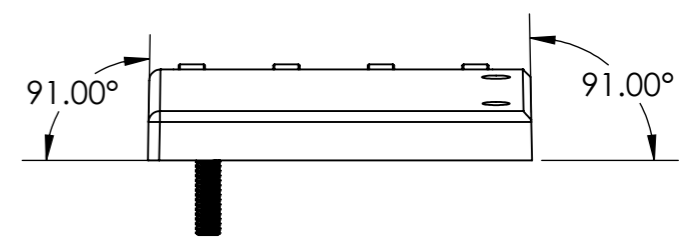
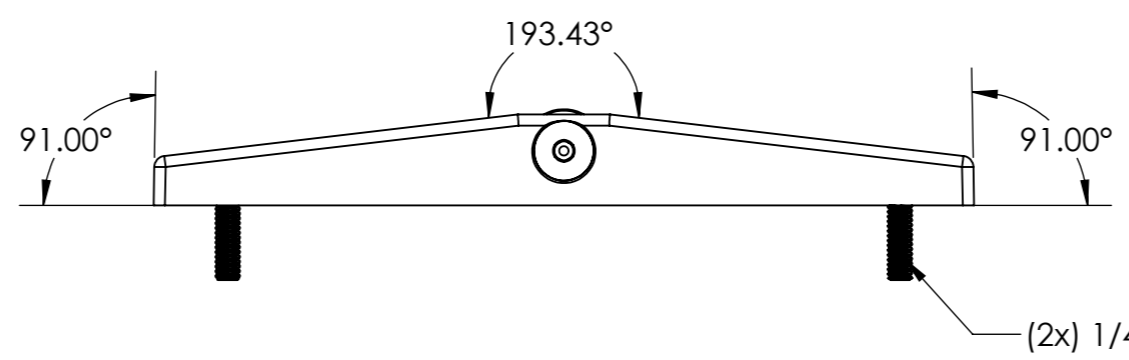
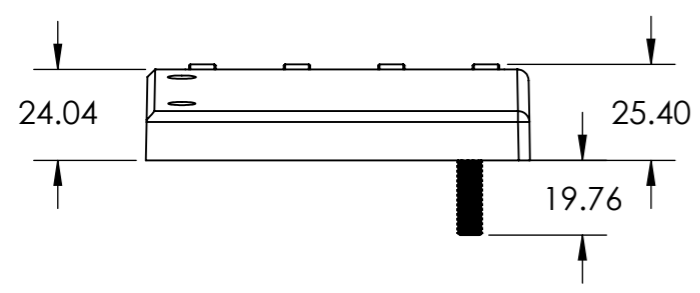

C

C

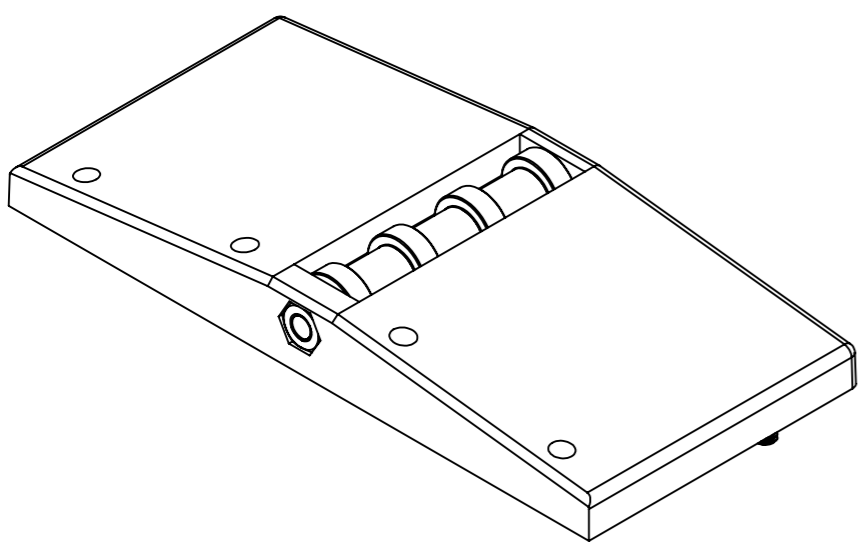
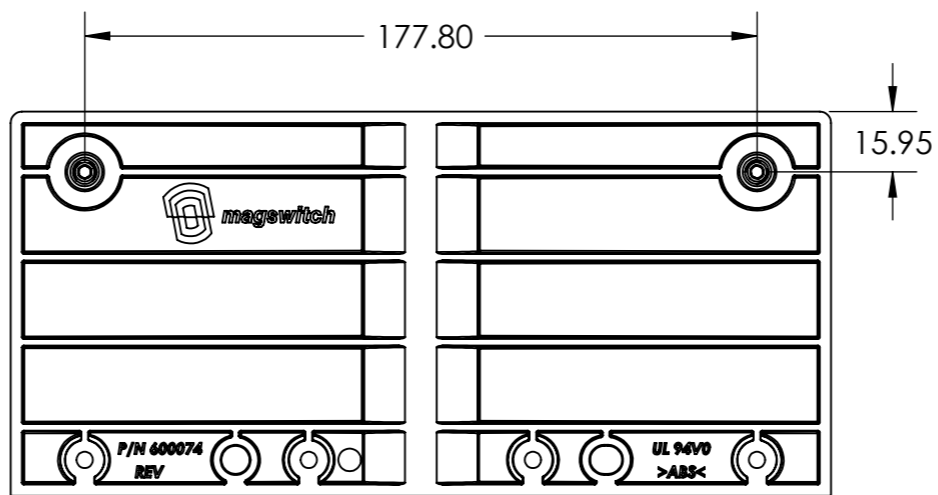

D

D

THIS DOCUMENT, AND THE INFORMATION IT CONTAINS, INCLUDING THE PRINCIPLES OF DESIGN, IS THE EXCLUSIVE PROPERTY OF MAGSWITCH TECHNOLOGY WORLDWIDE AND IS CONFIDENTIAL. ACCORDINGLY, THIS INFORMATION IS SUBMITTED TO YOU WITH THE AGREEMENT THAT IT IS NOT TO BE REPRODUCED, COPIED, OR LOANED IN PART OR IN WHOLE, NOR IS THE INFORMATION TO BE RELAYED TO ANY OTHER INDIVIDUAL OR COMPANY EXCEPT AS MTW FIRST AUTHORIZES IN WRITING. ACCEPTANCE OF THIS DOCUMENT CONSTITUTES AGREEMENT TO THESE RESTRICTIONS.

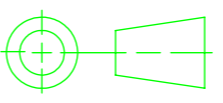
INTERPRET DRAWING PER: ISO 2768-M	DRAWN Y. Yan	DATE 4/4/2013
DIMENSIONS ARE IN MILLIMETERS	DESIGN	DATE
 THIRD ANGLE PROJECTION DO NOT SCALE	STD. CHECK	DATE
	F/F CHECK	DATE
	APPROVED	DATE

 8774 YATES DRIVE, SUITE 140
WESTMINSTER, COLORADO 80031
303-468-0662 / FAX 303-951-9918

TITLE: **Resaw Guide**

SIZE B	CAGE CODE	DWG. NO. 8110125	REV 01
SCALE 1:2		WEIGHT: g	SHEET 1 OF 1

1

2

3

4

5

6